

ROBSTRIDE 00 - ¥ 598

准直驱14N.m一体化电机模组
14N.m Integrated QDD Actuator

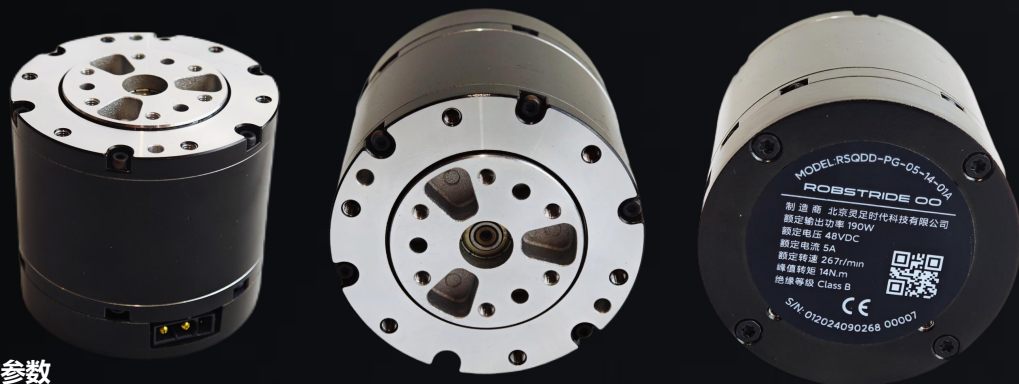

尺寸参数 Dimensions

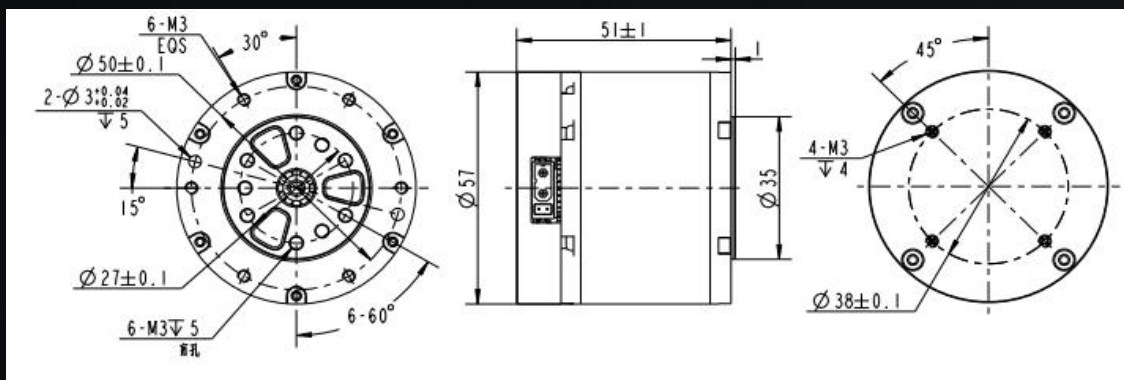

机械参数 Mechanical Specs

科目 Item	参数 Spec
重量 Weight	310g ±3g
极数 Pole	28
相数 Phase	3
驱动方式 Drive Method	FOC
减速比 reduction ratio	10 : 1

性能曲线 Performance Curves

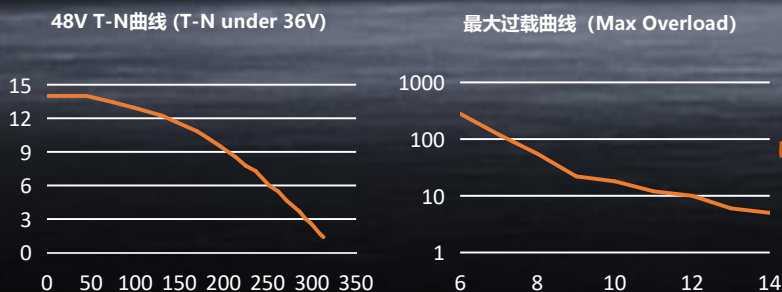

电气特性 Electrical Specs



科目 Item	参数 Spec
磁编码器 Magnetic Encoder	2 pcs
额定电压 Rated Voltage	48V
使用电压范围 Voltage Range	24-60V
额定输出功率 Rated Output Power	50w ±10%
额定扭矩 Rated Torque	5N.m
峰值扭矩 Peak Torque	14N.m
运转方向 Running Direction	CW/CCW
使用温度范围 Temperature Range	-20~50°C
使用湿度范围 Humidity Range	5~85%
保存温度范围 Storage Temperature Range	-30~70°C
绝缘等级 Insulation Level	Class B
空载转速 No-load Speed	315 rpm ± 10%
空载电流 No-load Current	0.5 Arms
额定负载转速 Rated Load Speed	100 rpm ± 10%
额定负载相电流 Rated Load Phase Current	4.7Apk ± 10%
峰值相电流 Peak Phase Current	15.5Apk ± 10%
绝缘电阻/定子绕组 Insulation Resistance/ Stator Winding	DC 500VAC, 100M Ohms
耐高压/定子与机壳 High Voltage Resistance/ Stator and Casing	600VAC, 1s, 2mA
电机反电势 Back-EMF	0.095 Vrms/rpm ±10%
线电阻 Line Resistance	1.5±10%Ω
转矩常数 Torque Constant	1.48 N.m/Arms
电机电感 Inductance	750±20μH

负载 Load (N.m)	工作时间 Operating Time (s)
5	rated
7	120
10	18
12	10
14	5