

ROBSTRIDE 02 IP67 - ¥999

准直驱17N.m一体化电机模组
17N.m Integrated QDD Actuator

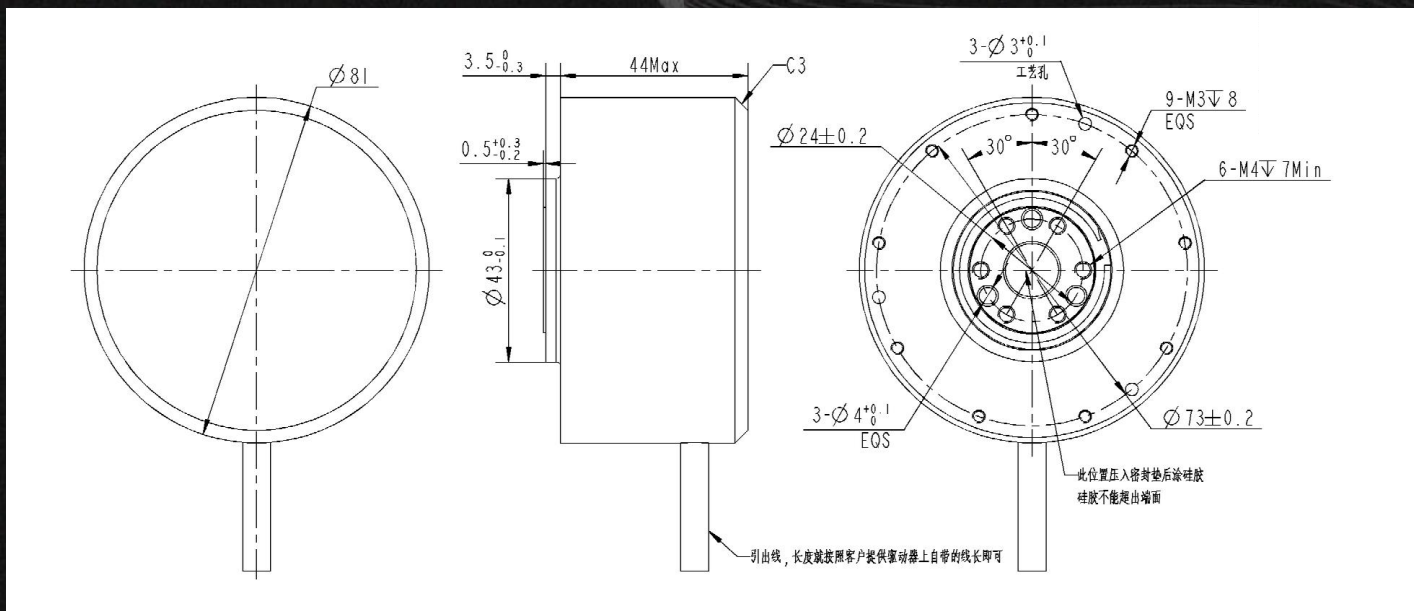

尺寸参数 Dimensions



ROBSTRIDE 02 IP67 - ¥999

准直驱17N.m一体化电机模组
17N.m Integrated QDD Actuator

电气特性 Electrical Specs



机械参数 Mechanical Specs

科目 Item	参数 Spec
重量 Weight	490g
极数 Pole	28
相数 Phase	3
驱动方式 Drive Method	FOC
减速比 reduction ratio	7.75 : 1
齿轮工艺 Gear Material	机加工钢Machined Steel
防水等级	IP67

性能曲线 Performance Curves

48V T-N曲线 (T-N under 48V)

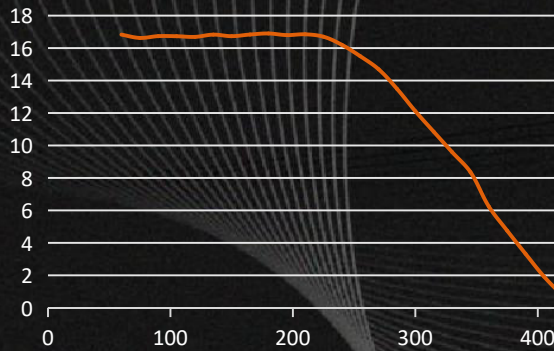

性能曲线 Performance Curves

最大过载曲线 (Max Overload)

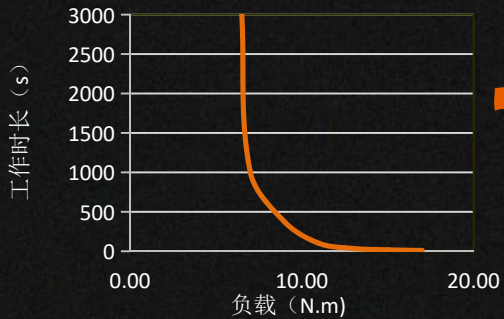

负载 Load (N.m)	工作时间 Operating Time (s)
6	rated
6.5	3000
11	100
15	18
17	10

科目 Item	参数 Spec
磁编码器 Magnetic Encoder	2 pcs
额定电压 Rated Voltage	48V
使用电压范围 Voltage Range	24-60V
额定输出功率 Rated Output Power	60w ±10%
额定扭矩 Rated Torque	6N.m
峰值扭矩 Peak Torque	17N.m
运转方向 Running Direction	CW/CCW
使用温度范围 Temperature Range	-20~50°C
使用湿度范围 Humidity Range	5~85%
保存温度范围 Storage Temperature Range	-30~70°C
绝缘等级 Insulation Level	Class B
空载转速 No-load Speed	410 rpm ± 10%
空载电流 No-load Current	0.5 Arms
额定负载转速 Rated Load Speed	100rpm ± 10%
额定负载相电流 Rated Load Phase Current	7Apk ± 10%
峰值相电流 Peak Phase Current	23Apk ± 10%
绝缘电阻/定子绕组 Insulation Resistance/ Stator Winding	DC 500VAC, 100M Ohms
耐高压/定子与机壳 High Voltage Resistance/ Stator and Casing	600VAC, 1s, 2mA
电机反电势 Back-EMF	0.096 Vrms/rpm ±10%
线电阻 Line Resistance	0.55Ω
转矩常数 Torque Constant	1.22 N.m/Arms
电机电感 Inductance	486±20%μH