

ROBSTRIDE 05 - ¥499

准直驱5.5N.m一体化电机模组
5.5N.m Integrated QDD Actuator

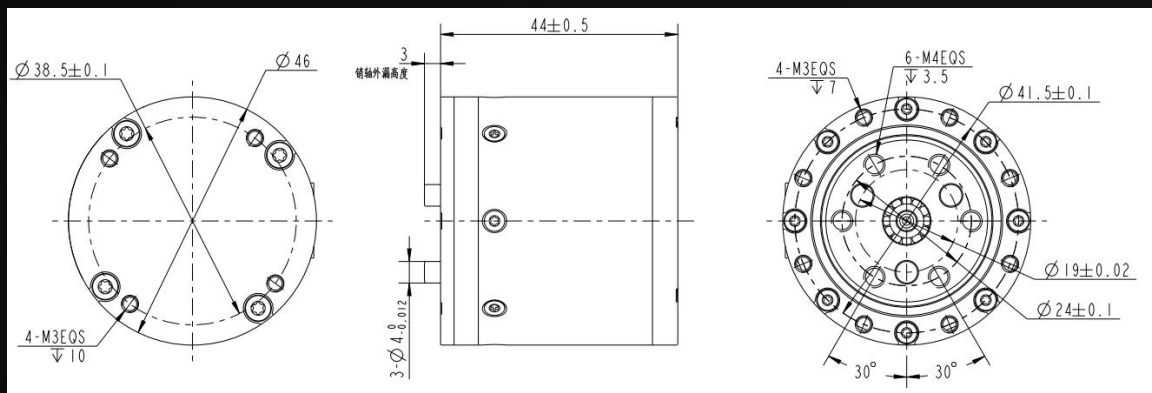

尺寸参数 Dimensions



机械参数 Mechanical Specs

科目 Item	参数 Spec
重量 Weight	191g
极数 Pole	20
相数 Phase	3
驱动方式 Drive Method	FOC
减速比 reduction ratio	7.75

性能曲线 (TBD) Performance Curves

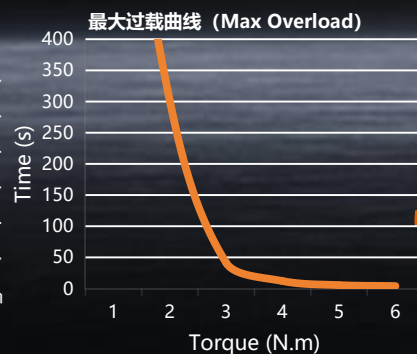
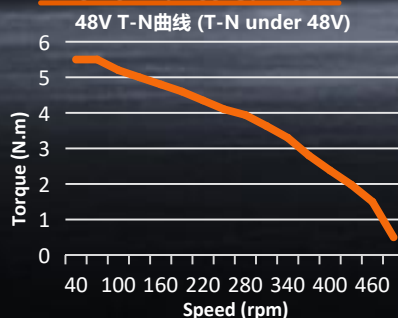

电气特性 Electrical Specs



科目 Item	参数 Spec
磁编码器 Magnetic Encoder	2pcs
额定电压 Rated Voltage	48V
使用电压范围 Voltage Range	15-60V
额定输出功率 Rated Output Power	17W±10%
额定扭矩 Rated Torque	1.6N.m
峰值扭矩 Peak Torque	5.5N.m
运转方向 Running Direction	CW/CCW
使用温度范围 Temperature Range	-20~50°C
使用湿度范围 Humidity Range	5~85%
保存温度范围 Storage Temperature Range	-30~70°C
绝缘等级 Insulation Level	Class B
空载转速 No-load Speed	480 rpm ± 10%
空载电流 No-load Current	0.14 Arms ± 10%
额定负载转速 Rated Load Speed	100 rpm ± 10%
额定负载相电流 Rated Load Phase Current	2.4Apk ± 10%
峰值相电流 Peak Phase Current	11Apk ± 10%
绝缘电阻/定子绕组 Insulation Resistance/ Stator Winding	DC 500VAC, 100M Ohms
耐高压/定子与机壳 High Voltage Resistance/ Stator and Casing	600VAC, 1s, 2mA
电机反电势 Back-EMF	7.4Vrms/krpm ± 10%
线电阻 Line Resistance	2.72Ω ± 10%
转矩常数 Torque Constant	0.94N.m/Arms
电机电感 Inductance	0.813mH ± 10%

负载 Load (N.m)	工作时间 Operating Time (s)
1.6	Rated
2	300
3	41
4	12
5	5.5
5.5	4